



U72 series

Bill Acceptors
User Guide



Thank you for choosing TOP VME .



Table Of Contents



1.Introduction.....	1
1-1.Overview	1
1-2. Features.....	1
2.Specification.....	1
2-1.General.....	1
2-2.Electronic.....	1
2-3.Machine.....	2
3.Packing List.....	2
4.Dimension	3
5.Installation.....	6
5-1.Harness Application.....	6
5-2.I/O Circuit.....	14
5-3.DIP Switch Setting	17
5-3-1.DIP Switch NO.3.....	18
5-4.Software download.....	19
6.Maintenance	20
6-1.To clean the internal parts	20
7.Troubleshooting.....	21



U72 Series

1. Introduction

1-1. Overview

U72 Series is a bill acceptor which features not only high-security module with bill box but also outstanding recognition and acceptance rate up to 96% or even greater.

1-2. Features

- Auto-calibrating.
- Easy maintenance.
- Detective bill-full mechanism.

2. Specification

2-1. General

Acceptance Rate	96% or greater
Bill Insertion	Four way acceptable
Interface	Pulse / RS232 / MDB
Installation	Indoor

2-2. Electronic

Power Source	10~42V DC (110V AC - purchase)
Power Consumption	12V-Standby : 0.13A/1.6W Operation Current : 1A/12W
	24V-Standby : 0.08A/2W Operation Current : 0.65A/16W
	34V- Standby : 0.07A/2.4W Operation Current : 0.52A/18W
	110V- Standby : 0.032A/3.52W Operation Current : 0.13A/14.3W
Temperature Range	Operating Temperature : 0° C~60° C
	Storage Temperature : -10° C~80° C
	Humidity : 20%~70%RH (no condensation)

2-3. Machine

Weight	Approx. 1.5 KG
Outline Dimension	238 x 94 x 139 mm
Bill Accepted Width	62 - 72 mm
Bill Capacity	Approx. 500 / 300 bills

3. Packing List

Accessories	U72 Series Bill Acceptors
	Harness (Please refer to P.4)
	Installation Guide
	External label
	Metal frame
	110V Power Converter (purchase)



U72 Series

4. Dimension

U72-N -P5

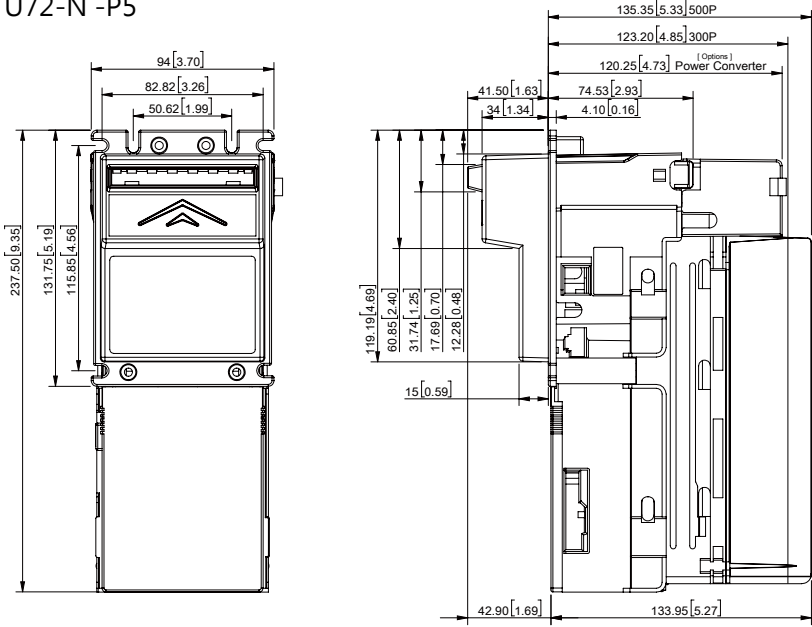

U72 -P5

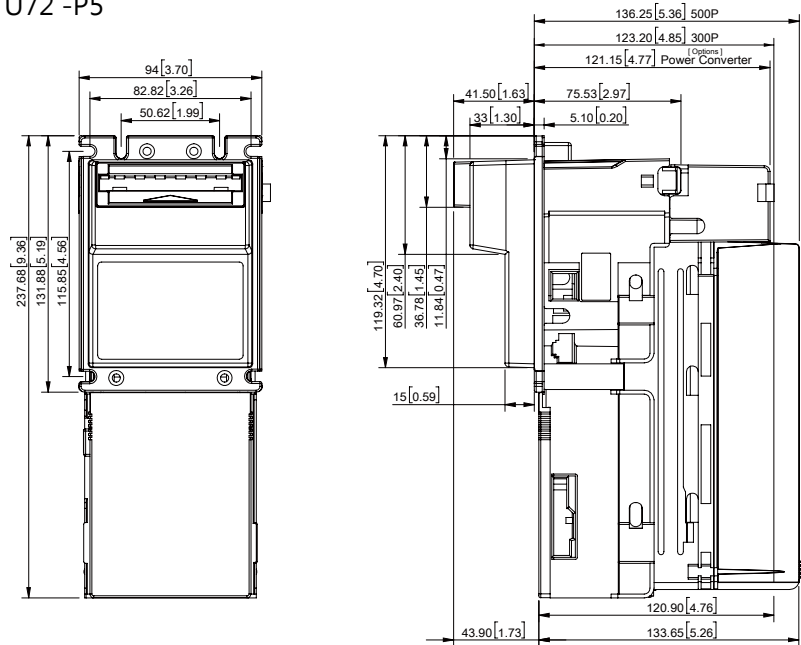

5. Installation

5-1. Harness Application

Interface	Voltage	Usage	Harness NO.	Page
MDB	34V DC	Power & Data Communication	WEL-RM006	7
Pulse	12V DC 24V DC	Power & Data Communication	WEL-RV701	8
		Extension Cable	CU-R961-1	9
RS232		Data Communication	WEL-R7U06	10
USB		Data Communication	2WIR-CP2102N--00	11
Pulse	110V AC	Power & Data Communication	2WIR-U72-110--0A (110V Options)	12
Pulse	12V DC	Power & Data Communication	2WIR-U72-110--0B (110V Options)	13



HARNESS FORMAT

WEL-RM006

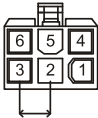
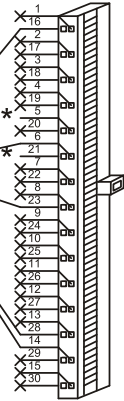
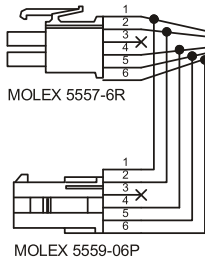

.163inch or 4.14 mm

MOLEX 5557-6R BACK VIEW

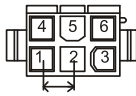

.163or4.14

MOLEX 5559-06P BACK VIEW

PIN NO	COLOR	PIN DEFINE
PIN1	BLUE	34V DC
PIN2	YELLOW	34V DC (RETURN)
PIN3	N/C	N/C
PIN4	ORANGE	MASTER TRANSMIT
PIN5	RED	MASTER RECEIVE
PIN6	GREEN	COMMUNICATIONS COMMON

PIN NO	COLOR	PIN DEFINE
PIN6	ORANGE	MASTER RECEIVE
PIN14	RED	MASTER TRANSMIT
PIN16	YELLOW	34V DC
PIN23	BLUE	34V DC (RETURN)
PIN28	GREEN	COMMUNICATIONS COMMON

Topvme

HARNESS FORMAT

WEL-RV701

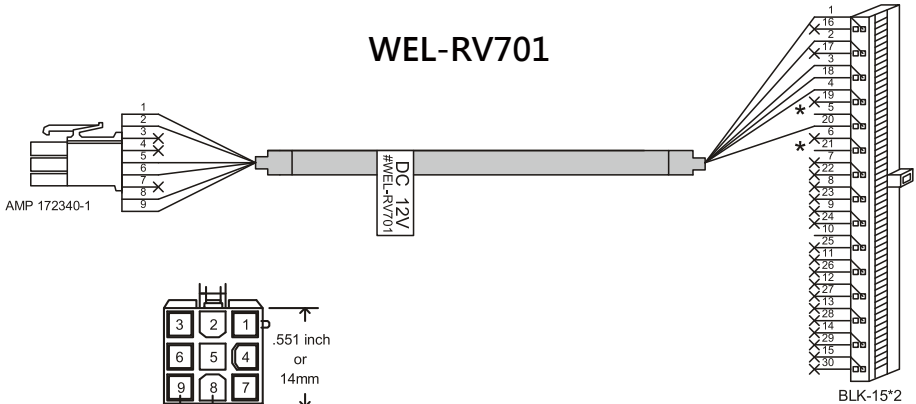

AMP 172340-1 BACK VIE
 .165inch or 4.2mm
 .551 inch or 14mm
 +AMP

PIN NO	COLOR	PIN DEFINE
PIN1	YELLOW	INHIBIT +
PIN2	GREEN	INHIBIT -
PIN3	RESRVED	
PIN4	RESRVED	
PIN5	RED	+12V DC
PIN6	RESRVED	
PIN7	BLUE	CREDIT_RELAY _(N.O.)
PIN8	PURPLE	CREDIT_RELAY _(COM)
PIN9	ORANGE	GND

PIN NO	COLOR	PIN DEFINE
PIN1	PURPLE	CREDIT_RELAY _(COM)
PIN2	BLUE	CREDIT_RELAY _(N.O.)
PIN3	RED	+12V DC
PIN4	YELLOW	INHIBIT +
PIN18	GREEN	INHIBIT -
PIN20	ORANGE	GND

Topvme



HARNESS FORMAT

CU-R961-1

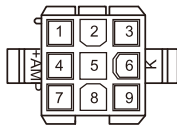
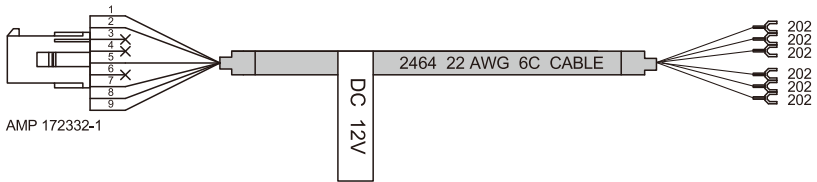

AMP 172332-1
BACK VIEW

PIN NO	COLOR	PIN DEFINE
PIN1	YELLOW	INHIBIT+
PIN2	GREEN	INHIBIT-
PIN5	RED	+12V DC
PIN7	BLUE	METER+
PIN8	PURPLE	METER-
PIN9	ORANGE	GND



HARNESS FORMAT

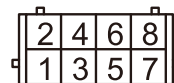
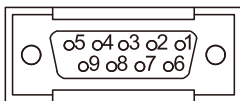
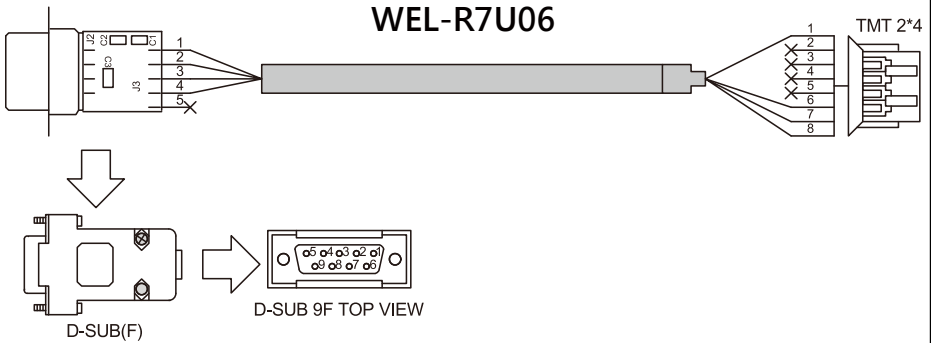

TMT 2*4 BACK VIEW

PIN NO	PIN DEFINE
PIN2	TXD
PIN3	RXD
PIN5	GND

PIN NO	COLOR	PIN DEFINE
PIN1	BLUE	GND
PIN6	WHITE	VCC
PIN7	BLACK	RXD
PIN8	PURPLE	TXD

Topvme



HARNESS FORMAT

2WIR-CP2102N--00

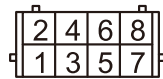
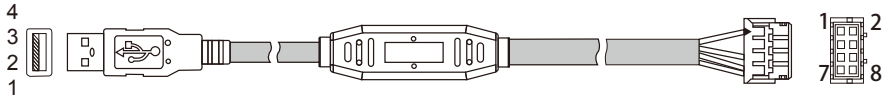

TMT 2*4 BACK VIEW

PIN NO	PIN DEFINE
PIN1	GND
PIN2	USB DP
PIN3	USB DM
PIN4	USB +5V

PIN NO	COLOR	PIN DEFINE
PIN1	BLUE	GND
PIN6	WHITE	NC
PIN7	BLACK	RXD
PIN8	PURPLE	TXD

Topvme

HARNESS FORMAT

2WIR-U72-110--0A

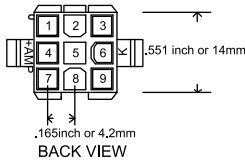
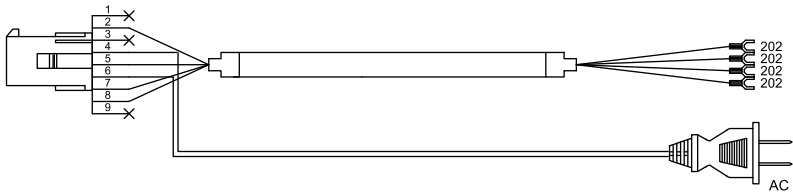

PIN NO	COLOR	PIN DEFINE
PIN1	YELLOW	INHIBIT +
PIN2	RED	INHIBIT-
PIN3	ORANGE	RESERVED
PIN4	BLACK	110V AC HOT (POWER)
PIN5	GREEN	Earth-Gronud
PIN6	BLACK	110V AC NEUTRAL(POWER)
PIN7	BLUE	CREDIT RELAY(N.O.)
PIN8	PURPLE	CREDIT RELAY(Common)
PIN9	X	X

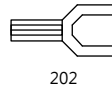

COLOR	PIN DEFINE
YELLOW	INHIBIT +
RED	INHIBIT-
ORANGE	RESERVED
GREEN	Earth-Gronud
BLUE	CREDIT RELAY(N.O.)
PURPLE	CREDIT RELAY(Common)

Topvme

HARNESS FORMAT

2WIR-U72-110--0B

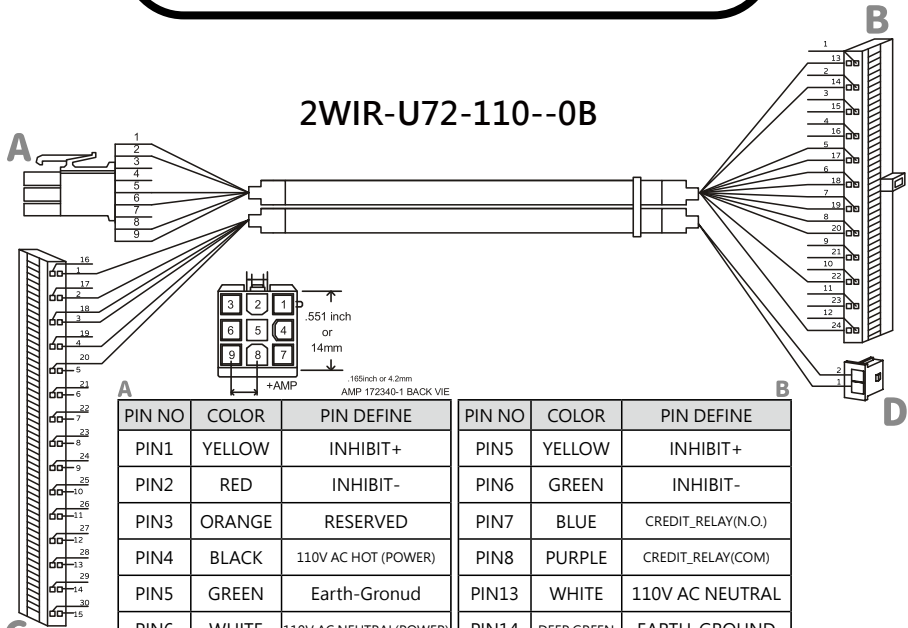

PIN NO	COLOR	PIN DEFINE
PIN1	YELLOW	INHIBIT+
PIN2	RED	INHIBIT-
PIN3	ORANGE	RESERVED
PIN4	BLACK	110V AC HOT (POWER)
PIN5	GREEN	Earth-Gronud
PIN6	WHITE	110V AC NEUTRAL(POWER)
PIN7	BLUE	CREDIT RELAY(N.O.)
PIN8	PURPLE	CREDIT RELAY(Common)
PIN9	RESERVED	X

PIN NO	COLOR	PIN DEFINE
PIN5	YELLOW	INHIBIT+
PIN6	GREEN	INHIBIT-
PIN7	BLUE	CREDIT_RELAY(N.O.)
PIN8	PURPLE	CREDIT_RELAY(COM)
PIN13	WHITE	110V AC NEUTRAL
PIN14	DEEP GREEN	EARTH_GROUND
PIN17	YELLOW	INHIBIT+
PIN18	RED	INHIBIT-
PIN19	BLUE	CREDIT_RELAY(N.O.)
PIN20	PURPLE	CREDIT_RELAY(COM)
PIN22	ORANGE	RESERVED
PIN24	BLACK	110V AC HOT

PIN NO	COLOR	PIN DEFINE
PIN1	PURPLE	CREDIT_RELAY(COM)
PIN2	BLUE	CREDIT_RELAY(N.O.)
PIN3	RED	12V DC
PIN4	YELLOW	INHIBIT +
PIN18	GREEN	INHIBIT-
PIN20	ORANGE	GND

PIN NO	COLOR	PIN DEFINE
PIN1	RED	DC 12V
PIN2	ORANGE	GND

Topvme

5-2. I/O Circuit

MDB Interface

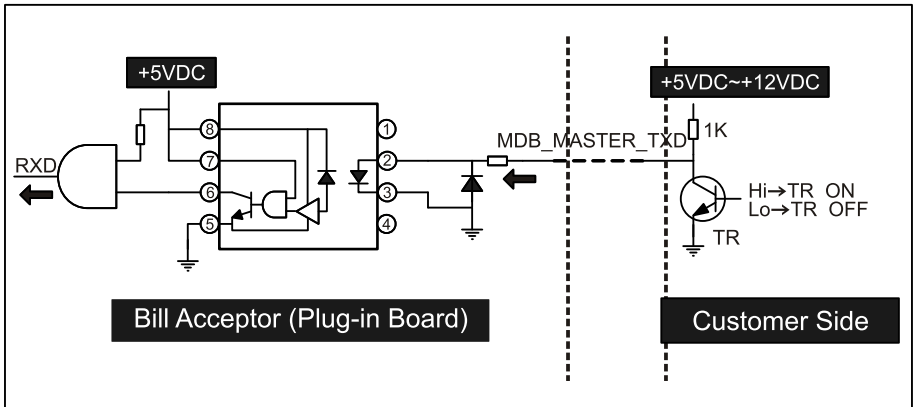
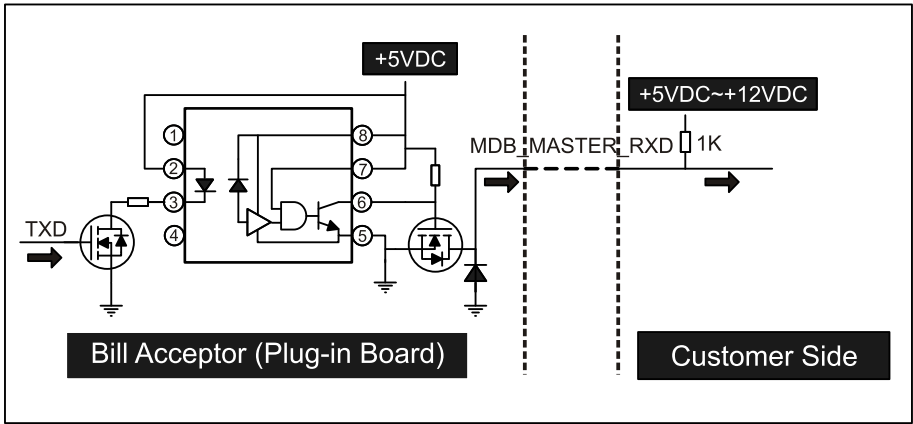



Pulse Interface

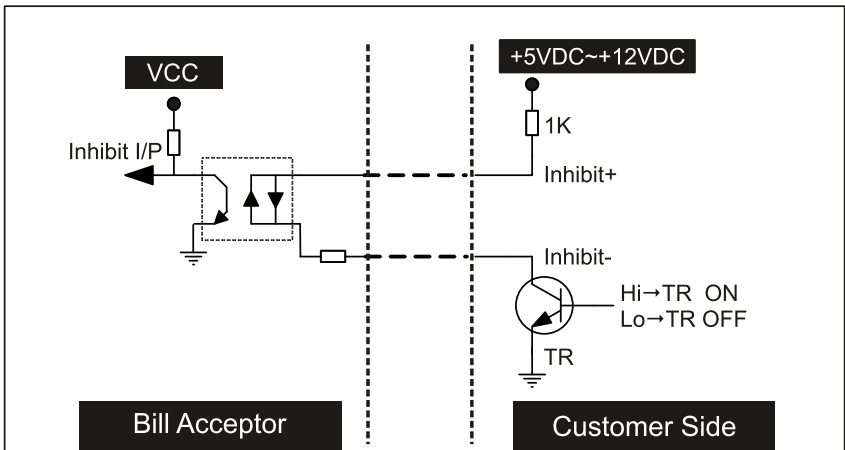
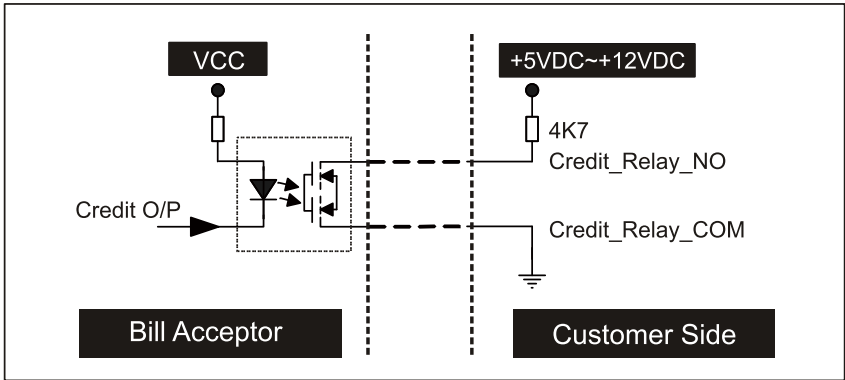

BA Status	DIP SW Setting		Control Signal
Inhibit	Inhibit Active	Low	Low
		High	High
Enable	Inhibit Active	Low	High
		High	Low

RS232 Interface

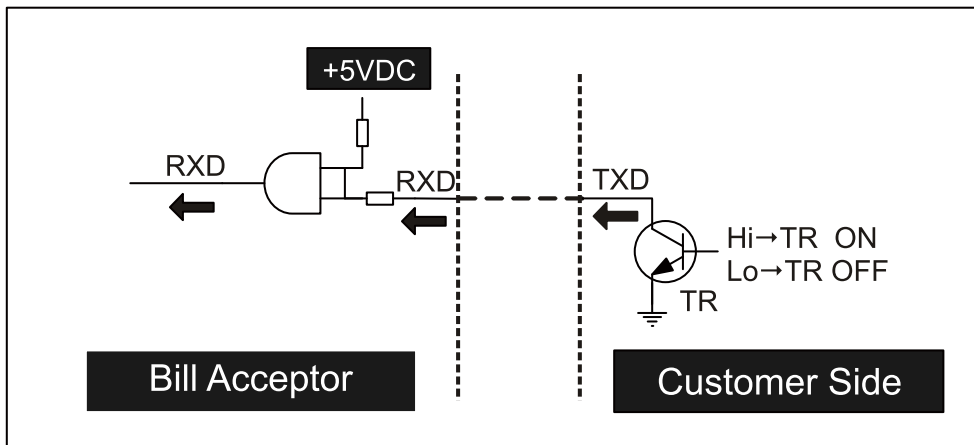
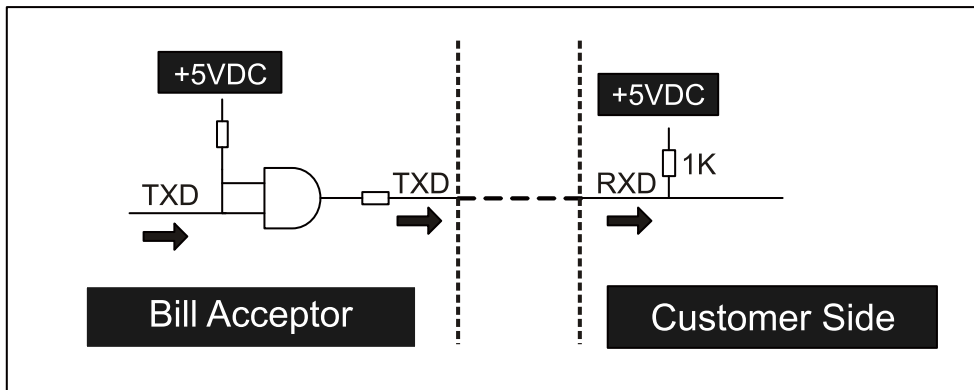

5-3. DIP Switch Setting

Three dip switches are located on (1,2) both sides of the U72 series, and (3) the CPU board.

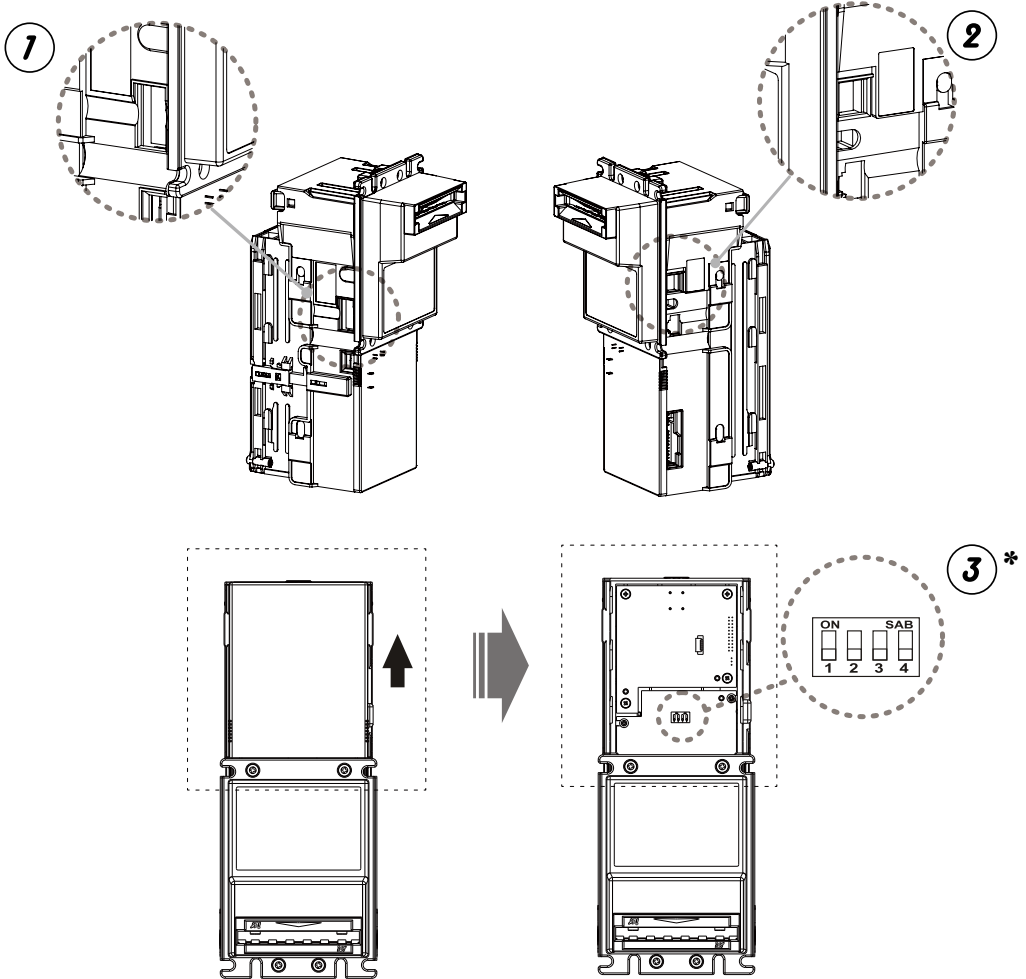

5-3-1. DIP Switch NO.3

1. MDB Interface

1	2	3	4
OFF	OFF	OFF	OFF

2. Pulse Interface

		1	2
ON		Normal High	V
OFF		Normal Low	

USD1 = # pulse (s)		3	
		ON	OFF
4	ON	20	2
	OFF	4	1

3. RS232 Interface

1	2	3	4
ON	OFF	OFF	ON



5-4. Software download

Please refer to the G-BOX Operation manual for a guide step by step how to download or update using the G-Box programmer. You can obtain it from your local agent or contact us at : service@topvme.com.tw

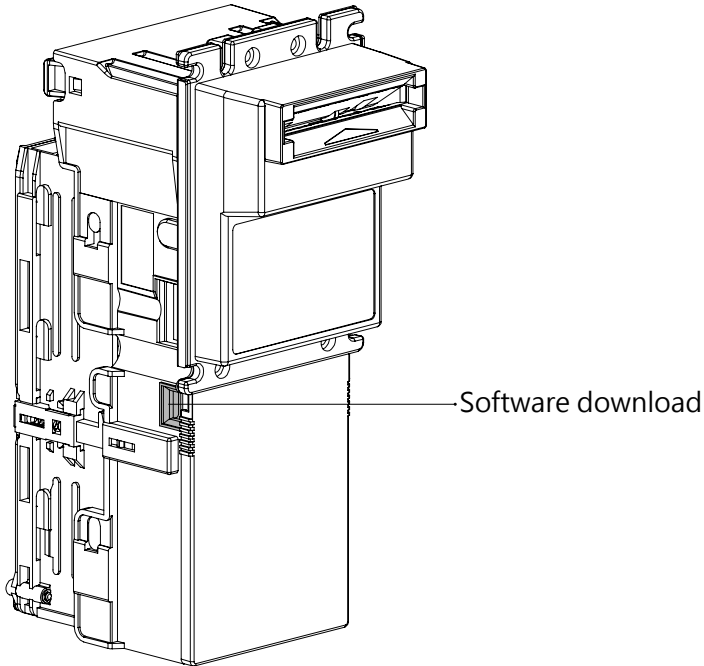

6. Maintenance

To make sure the bill acceptor always works smoothly, please clean the internal parts regularly.

6-1. To clean the internal parts

1. Press the buttons on the sides of bill path and pull the unit out.

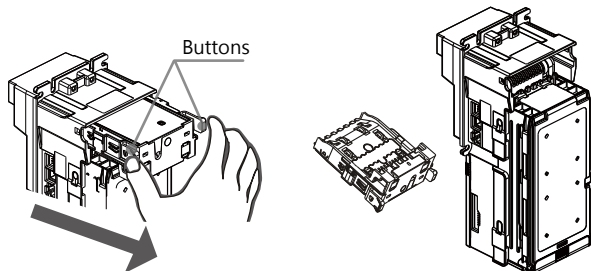

2. Use a soft, dry cloth or towel to clean the bill path and sensors.

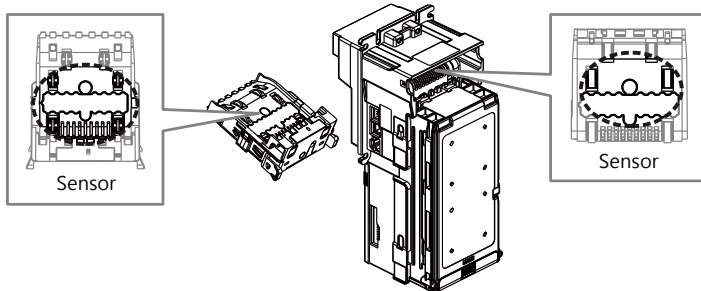

	Maintenance Notice	
	<i>(Any improper maintenance will result invalid warranty.)</i>	
	Recommended	Mild, non-abrasive, a small amount of soapy water.
	DO NOT USE	Organic solvent, Alcohol, Volatile liquid.

7. Troubleshooting

LED Flashes	Status	Corrective Actions	
1	GREEN	White Card Calibration.	a small amount of soapy water
1	RED	Bill jammed.	Remove the bill box by sliding the top button and the bill path, and then remove the jammed bill.
2	RED	Disable.	Inspect for right DIP switch setting.
3	RED	Recognition sensor error.	Inspect for foreign objects on sensor or bill path and clean.
3+2	RED	Hook sensor error.	Inspect for foreign objects on security hook and clean.
4	RED	Anti-string sensor error or a stringing attempt has detected.	Inspect for foreign objects on sensor or bill path and clean.
5	RED	Bill box has been removed.	Replace the bill box.
6	RED	Stacker error or stacker full.	Inspect the stacker/empty the stacker.
7	RED	Motor error.	Inspect for foreign objects on bill path and clean.

Note: LED light is the entrance light

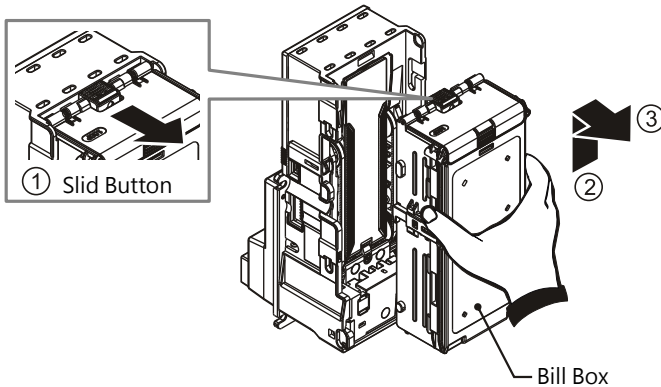

If the error can not be solved after corrective actions or happen again, please contact TOP for technical support.



Top Vending Machine Electronics Co., Ltd.

NO.11, Anzhong St., Luzhu Dist., Taoyuan City338, Taiwan, (R.O.C.)

Phone : +886-3-3115969 · Fax : +886-3-3115970

E-mail : sales@topvme.com.tw

Website : www.topvme.com

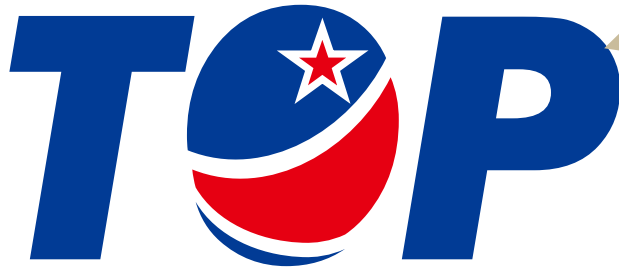

Top Vending Machine Electronics Co., Ltd.



www.topvme.com